



CH20W

**20 CUE WATERPROOF
WIRELESS FIRING SYSTEM**

USER MANUAL v.2.2

CONTENTS

1	DISCLAIMER.....	1
2	SAFETY.....	1
3	GLOSSARY.....	1
4	DESCRIPTION.....	1
5	ACCESSORIES.....	2
6	CHARGING THE SYSTEM.....	2
7	BASIC OPERATION.....	3
	7.1 Igniters	3
	7.2 Change Modes.....	4
	7.3 Fire procedure.....	4
	7.4 Transmitter Controls.....	5
	7.5 Receiver Controls.....	5
	7.6 Receiver Mode.....	5
	7.7 Program a receiver with a transmitter.....	6
8	SEQUENCER OPERATION.....	6
	8.1 Same Time Delay between CUES.....	6
	8.2 Different time delay between CUES.....	6
9	EXPANDING THE SYSTEM.....	7
	9.1 Example 1.....	7
	9.2 Example 2.....	7
	9.3 Example 3.....	8
	9.4 Example 4.....	8
10	LINK THE RECEIVERS.....	9
	10.1 Receiver considerations.....	9
	10.2 Setting the receiver number.....	9
	10.3 Example 1.....	10
	10.4 Example 2.....	10

1 DISCLAIMER

The manufacturer(s), distributor(s) and / or seller(s) accept no responsibility whatsoever for any damage, injury or loss, financial or otherwise, resulting directly or indirectly from the use, misuse, function or malfunction of this device. By purchasing and using this device you understand and accept this disclaimer.

2 SAFETY

Safety is the user's responsibility.

All pyrotechnic effect and firework safety guidelines should be followed completely.

3 GLOSSARY

Term	Description
Button	A button on the Handheld Transmitter. Usually buttons 1 - 20.
Sequencer	A function that allows Cues to fire automatically.
Step Fire	A function that fires Cues sequentially one after the other.
All Fire	A function that fires all the Cues.
Direct Fire	The operator can fire any Cue on command.
Indirect Fire	The operator can only fire Cues in Sequence, Step or All Fire.
Pair	Teach a receiver a Transmitter Identity.
Transmitter Identity	Each transmitter has a unique identity. Each transmitter has 4 further sub-identities selected from the transmitter slide switch. A receiver can be paired with any 2 transmitter identities.

4 DESCRIPTION

CH20W is a 20 cue advanced wireless firing system for pyrotechnics and fireworks.

Using the standard hand held transmitter and extra receivers up to 60 Cues are available in Direct Fire mode. However there can be many more Cues than Buttons. You can program many receivers to operate in parallel (at the same time). So for example Button 1 may cause Cue 1 on several receivers to fire at the same time.

Each receiver can be programmed with 2 Transmitter Identities. This means the operator can fire many Cues on many receivers in parallel, and then fire individual Cues on individual receivers by changing the Transmitter Identity (see Section 9).

The system is expandable up to 320 Cues in CONTINUOUS or STEP fire mode using up to 16 receivers.

The desired firing mode has to be activated before the system is used. This means there is no possibility of accidentally starting the Sequencer or All Fire mode etc if it is not required. This greatly increases safety over the 2008 model.

See Section 7 for more details.

5 ACCESSORIES

The optional waterproof transmitter can be used with this system.



- Professional.
- Waterproof when closed.
- Start and Stop the Sequencer.
- Long range.
- Long battery life.
- Fire more Cues.
- Safe "2 Button" firing.
- Metal ARM key switch.
- FCC Approved.

6 CHARGING THE SYSTEM

Connect the charger to the connector marked "CH".

The system requires 15 volts DC @ 0.5 A.

The Battery Status Light will only operate when the unit is switched ON and in FIRE mode. However the system will charge even when switched OFF.

Battery Status Light	Description
RED (flashing)	Battery Low.
RED (steady)	Battery Charging.
RED / GREEN (flashing)	Battery Almost Full.
GREEN (steady)	Battery Full.

Lead Acid Batteries naturally discharge over time. To keep the battery in good condition it is recommended the system is charged every 3 months.

Storing the system in extremely low or high temperatures will shorten the life of the battery.

7 BASIC OPERATION

7.1 IGNITERS

Only fire a maximum of 2 standard pyrotechnic igniters in parallel per cue. Connecting more than 2 can cause the firing system to be damaged.

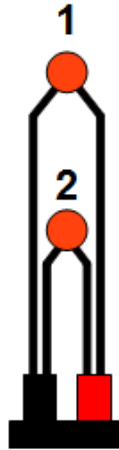

Parallel Connected Igniters

Only fire a maximum of 6 standard pyrotechnic igniters in series per cue. Connecting more than 6 can cause the igniters to fail.

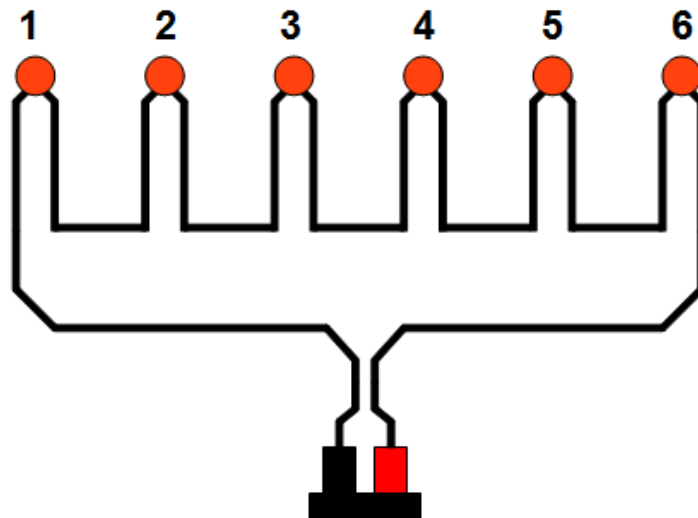

Series Connected Igniters

7.2 CHANGE MODES

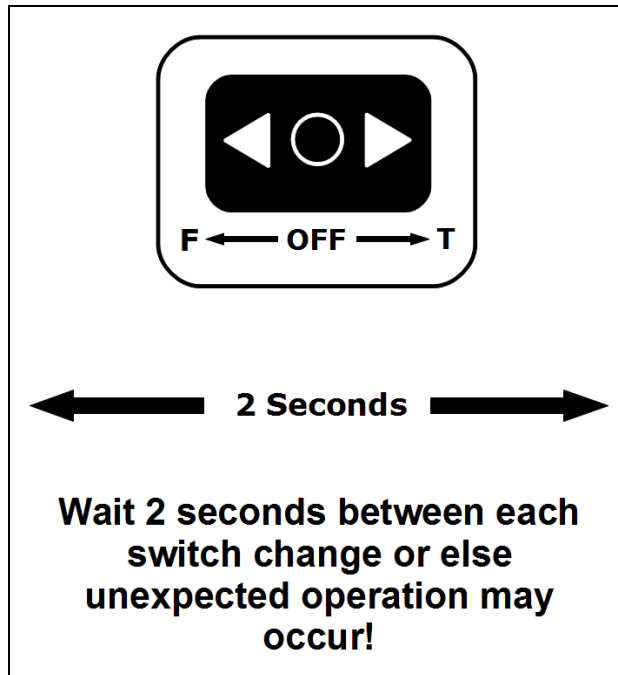

7.3 FIRE PROCEDURE

Note: *When using multiple receivers, it is advisable to clear and re-programme each receiver with the correct transmitter before use. This avoids the wrong transmitter accidentally triggering a receiver.*

For best results ensure the battery is fully charged.

For maximum safety follow the procedure below.

1. Attach the receiver antenna.
2. Clear the receiver and program it with a transmitter.
3. Set receiver into correct mode.
4. Ensure SAFETY SWITCH is keyed to OFF and POWER is set to OFF.
5. Connect igniters.
6. Set POWER to TEST.
7. Check for continuity.
8. Set POWER to FIRE.
9. Key SAFETY SWITCH to ON.
10. Ensure the area is safe and retreat to a safe distance.
11. Extend transmitter antenna.
12. Switch transmitter ON.
13. Set transmitter SLIDE SWITCH to correct position.
14. Fire!

7.4 TRANSMITTER CONTROLS

Button	Description
1 - 20	Fire individual Cue.
ALL	Fire all the Cues.
STEP	Fire the Cues sequentially (one after the other) with each successive button press.
CONT	Start the Sequencer.
Slide Switch (position 1,2,3,4)	Select the Transmitter Identity. Each transmitter is unique so 2 transmitters each set to Slide Position 1 will still have separate identities. The slide switch should be set in position 4 to link receivers together for Sequencer and Step fire functions (see Section 10). A receiver can be programmed with more than 1 transmitter or transmitter identity.

7.5 RECEIVER CONTROLS

Button	Description
POWER (FIRE, OFF, TEST)	Control the mode of the receiver. TEST mode tests the cues for continuity. OFF mode turns the receiver off. FIRE mode allows the system to be programmed and cues to be fired.
Safety Key Switch (ON, OFF)	This arm and disarms the system.
Program	Program the receiver with a new transmitter.
Up-Arrow	Increment the selected digit.
Right-Arrow	Cycle through digits and modes.
OK / Delete	Enter the current settings. Hold down until the display blinks to reset the receiver.
ADD (Address)	Set 1 of 16 possible receiver addresses for expansion up to 16 receivers.
T/M (Different Time Mode)	Allow a different time delay to be set between each Cue (see Section 8.2).

7.6 RECEIVER MODE

Receiver Mode	Description
SINGLE FIRE (SING)	Fire single Cues.
STEP FIRE (STEP)	Fire Cues one after the other on every press of the STEP button.
ALL FIRE(ALL)	Fire all the Cues.
SAME DELAY (SA X.XX.XX)	Sequence with the same delay between each Cue.
DIFFERENT DELAY (DI X.XX.XX)	Sequence with a different delay between each Cue.

To set the receiver mode:

1. Hold **OK** until the display blinks once.
2. Press **RIGHT-ARROW** to cycle through the modes.
3. Press **OK** to set the mode.

7.7 PROGRAM A RECEIVER WITH A TRANSMITTER

WARNING

Never program the receiver when another transmitter is transmitting. This may cause the receiver to be programmed with the wrong transmitter.

The receiver can be programmed with 2 Transmitter Identities if required.

To clear the receiver of stored transmitters:

1. Put POWER switch to **FIRE** position.
2. Hold the **PROGRAM** button until the program light goes out.

To program the receiver with a new transmitter:

1. Put POWER switch to **FIRE** position.
2. Set the transmitter identity using the transmitter SLIDE SWITCH.
3. Press and hold any button on the transmitter.
4. Press and release the **PROGRAM** button briefly.

The program light blinks twice to indicate the receiver has been programmed.

8 SEQUENCER OPERATION

The sequencer can be set up to use the same time delay between each Cue or a different time delay between each Cue.

The time delay is used when firing in *continuous* mode. The delay can be set from 0m00.00s to 9m59.99s.

The delay in either SAME or DIFFERENT mode will be stored even if the system is switched off. The delays can be reset by pressing the OK button for several seconds, until the display shows **SA 0.00.00**

SA X.XX.XX = Same time delay between each Cue.
DI X.XX.XX = Different time delay between each Cue.

8.1 SAME TIME DELAY BETWEEN CUES

1. Hold **OK** button until the display shows **SA 0.00.00**
2. Press **RIGHT-ARROW** to cycle through the digits.
3. Press **UP-ARROW** to increment the time delay.
4. Press **OK** to set the time delay.

The system is now ready to fire in continuous mode.

See Section 9 for details on how to link multiple receivers for a long sequence.

8.2 DIFFERENT TIME DELAY BETWEEN CUES

There are 19 delays to be set between 20 Cues.

Delay Number 1 = Delay between Cue 1 and Cue 2.

Delay Number 2 = Delay between Cue 2 and Cue 3.
Delay Number N = Delay between Cue N and Cue [N+1]

1. Hold **OK** button until the display shows **SA 0.00.00**
2. Press **RIGHT-ARROW** to select the 1st digit.
3. Press **T/M** to select DIFFERENT TIME mode.

The display shows **01 0.00.00**

4. Press **RIGHT-ARROW** to cycle through the digits.
5. Press **UP-ARROW** to increment the time delay.
6. Press **OK** to set the time delay.

Each time **OK** is pressed after setting a delay, the delay number increases. Once the final delay has been set the display reads **DI DIFF**. To review the time delays press the **T/M** button.

The system is now ready to fire in continuous mode.

9 EXPANDING THE SYSTEM

More receivers can be added to expand the system.

By programming the receivers with different Transmitter Identities, the receivers can be controlled in parallel (at the same time), individually or a mixture of both.

9.1 EXAMPLE 1

The receivers are programmed with the same Transmitter Identity so they are controlled in parallel (at the same time).

[With 1 handheld transmitter and 3 receivers]

Transmitter Identity 1 = Receiver A, Receiver B and Receiver C.

To do this:

1. Program receiver A, B and C with the transmitter slide switch in the same position.

9.2 EXAMPLE 2

The receivers are programmed with separate Transmitter Identities so that they are controlled separately.

[With 1 handheld transmitter and 2 receivers]

Transmitter Identity 1 = Receiver A.

Transmitter Identity 2 = Receiver B.

To do this:

1. Program receiver A with the transmitter slide switch in position '1'.
2. Program receiver A with the transmitter slide switch in position '2'.

9.3 EXAMPLE 3

The receivers can be programmed with more than 1 transmitter AND / OR Transmitter Identity AT THE SAME TIME. This means a group of receivers can have Cues fired simultaneously AND Cues fired separately.

[With 1 handheld transmitter and 3 receivers]

Transmitter Identity 1 = Receiver A and Receiver B and Receiver C.

Transmitter Identity 2 = Receiver A only.

Transmitter Identity 3 = Receiver B only.

To do this:

1. Program receiver A, B, and C with the transmitter slide switch in position '1'.
2. Program receiver A with the transmitter slide switch in position '2'.
3. Program receiver A with the transmitter slide switch in position '3'.

9.4 EXAMPLE 4

The receivers can be programmed with more than 1 transmitter AND / OR Transmitter Identity AT THE SAME TIME. This means a group of receivers can have Cues fired simultaneously AND Cues fired separately.

[With 1 waterproof professional transmitter and 6 receivers]

Transmitter Identity 1 = Receiver A, Receiver B, Receiver C and Receiver D.

Transmitter Identity 2 = Receiver E and Receiver F.

Transmitter Identity 3 = Receiver A only.

Transmitter Identity 4 = Receiver B only.

Transmitter Identity 5 = Receiver C only.

Transmitter Identity 6 = Receiver D only.

Transmitter Identity 7 = Receiver E only.

Transmitter Identity 8 = Receiver F only.

To do this:

1. Program receiver A, B, C and D with the transmitter selector dial in position '1'.
2. Program receiver E and F with the transmitter selector dial in position '2'.
3. Program receiver A with the transmitter selector dial in position '3'.
4. Program receiver B with the transmitter selector dial in position '4'.
5. Program receiver C with the transmitter selector dial in position '5'.
6. Program receiver D with the transmitter selector dial in position '6'.
7. Program receiver E with the transmitter selector dial in position '7'.
8. Program receiver F with the transmitter selector dial in position '8'.

10 LINK THE RECEIVERS

The receivers can be programmed so they are linked together. This allows long Sequencer or Step runs.

For example:

- An 80 cue Sequence could run across 4 receivers (4 x 20 cues).
- A 240 cue Sequence could run across 12 receivers (12 x 20 cues).
- 320 cues could be fired manually in Step mode (16 x 20 cues).

10.1 RECEIVER CONSIDERATIONS

Linking the receivers for use with a Sequence will only work if all the Cues have **the same time delay** (see Section 9.1). Each receiver is set with a 'receiver number' from 1 to 16 to determine when it will start in the sequence.

There is no communication between receivers, so when a receiver receives the signal to start the Sequencer, it waits a specific time delay before starting the sequencer. This gives the impression that the sequence flows from one receiver to the next.

This time delay is calculated by:

$$\text{Time to sequence begin} = \text{delay between Cues} \times 20 \times (\text{receiver number}-1)$$

For example:

Assume the time delay is set to 1 second and 4 receivers are in the system. Receiver A has Receiver Number 1, Receiver B has Receiver Number 2 etc.

When **CONT** button is pressed to start the sequence, all receivers receive the signal at the same time.

Receiver 1 starts to sequence immediately. Receiver 2 starts to sequence after 20 seconds. Receiver 3 starts to sequence after 40 seconds. Receiver 4 starts to sequence after 60 seconds etc.

Because there is no communication between receivers, if for example receiver 3 is OFF, then receivers 1, 2 and 4 will still operate, but with a 20 second gap between receivers 2 and 4.

10.2 SETTING THE RECEIVER NUMBER

Each receiver will need to be set up with a receiver number in the following way.

- 1 Press **ADD** button.
- 2 Use **RIGHT-ARROW** and **UP-ARROW** to set 1 of 16 addresses.
- 3 Press **ADD** button again.

All the receivers will need to be programmed with the transmitter in the usual way **except** the transmitter slide switch **must** be in position '4' at all times.

10.3 EXAMPLE 1

120 cues to be used in Sequence with a 2 second delay between each cue.

[With 1 handheld transmitter and 6 receivers]

To do this:

1. All receivers are programmed with the transmitter slide switch in position 4 (see Section 8).
2. Each receiver is set with a Receiver Number (see Section 11.2).
3. The time delay in SAME TIME mode is set up to be 2 seconds on all receivers.

Press **CONT** and all cues will fire in sequence with the programmed delay.

START >>> Receiver A Cues 1-20 >> Receiver B Cues 1-20 >> Receiver C Cues 1-20 >> Receiver D Cues 1-20 >> Receiver E Cues 1-20 >> Receiver F Cues 1-20 >>> END.

However, **CONT** will not be able to be used again until all receivers are switched OFF and ON again.

10.4 EXAMPLE 2

320 cues to be fired manually in Step mode.

[With 1 handheld transmitter and 16 receivers]

To do this:

1. All receivers programmed with the transmitter slide switch in position 4 (see section 8).
2. Each receiver is set with a Receiver Number (see Section 11.2).
3. The receiver is set to STEP mode.

The next cue will fire each time STEP is pressed.

START

STEP = Receiver A Cue 1 fires.

STEP = Receiver A Cue 2 fires.

STEP = Receiver A Cue 3 fires.

...

...

STEP = Receiver A Cue 19 fires.

STEP = Receiver A Cue 20 fires.

STEP = Receiver B Cue 1 fires.

STEP = Receiver B Cue 2 fires.

...

...

STEP = Receiver O Cue 19 fires,

STEP = Receiver O Cue 20 fires.

END

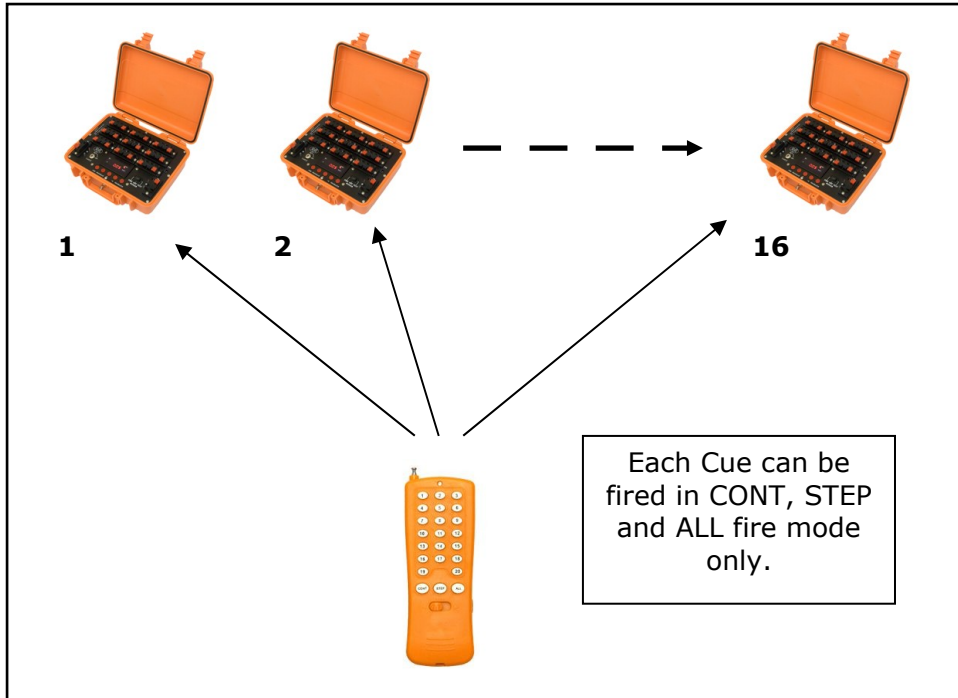

320 Cue Configuration

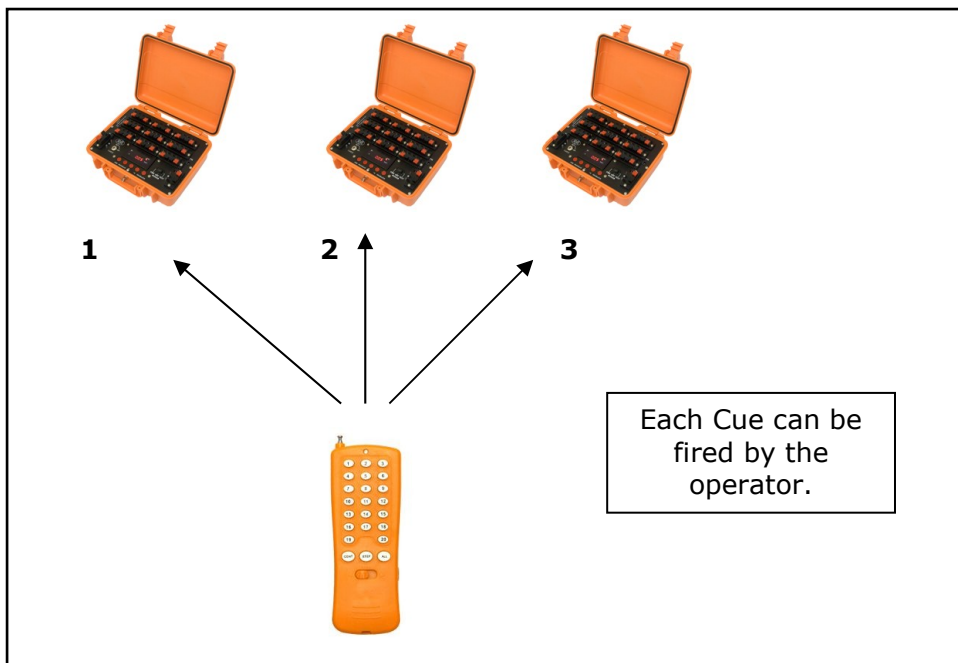

60 Cue Configuration